

## RAISED ACCESS FLOOR SYSTEM

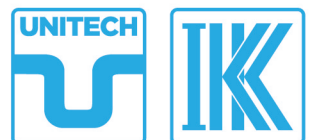

[www.unitech-ikk.com](http://www.unitech-ikk.com)  
[www.wikkgroup.com](http://www.wikkgroup.com)

# RAISED ACCESS FLOOR SYSTEM



# Index

· Scope of Application	4
· Benefits of Raised flooring	4
· Composition	5
· Standards	8
· Production/Inspection Standards	10
· PIXEL Chipboard Panel- PIX-WOOD	12
· PIXEL Steel/Cementitious Panel- PIX-STEEL	13
· PIXEL Calcium Sulphate Panel- PIX-CAL	14
· PIXEL UNDER-STRUCTURE SYSTEM	15
· VINYL COVERING	16
· PIXEL Perforated Panels	17
· PIXEL Raised Floor Service Power Boxes	18

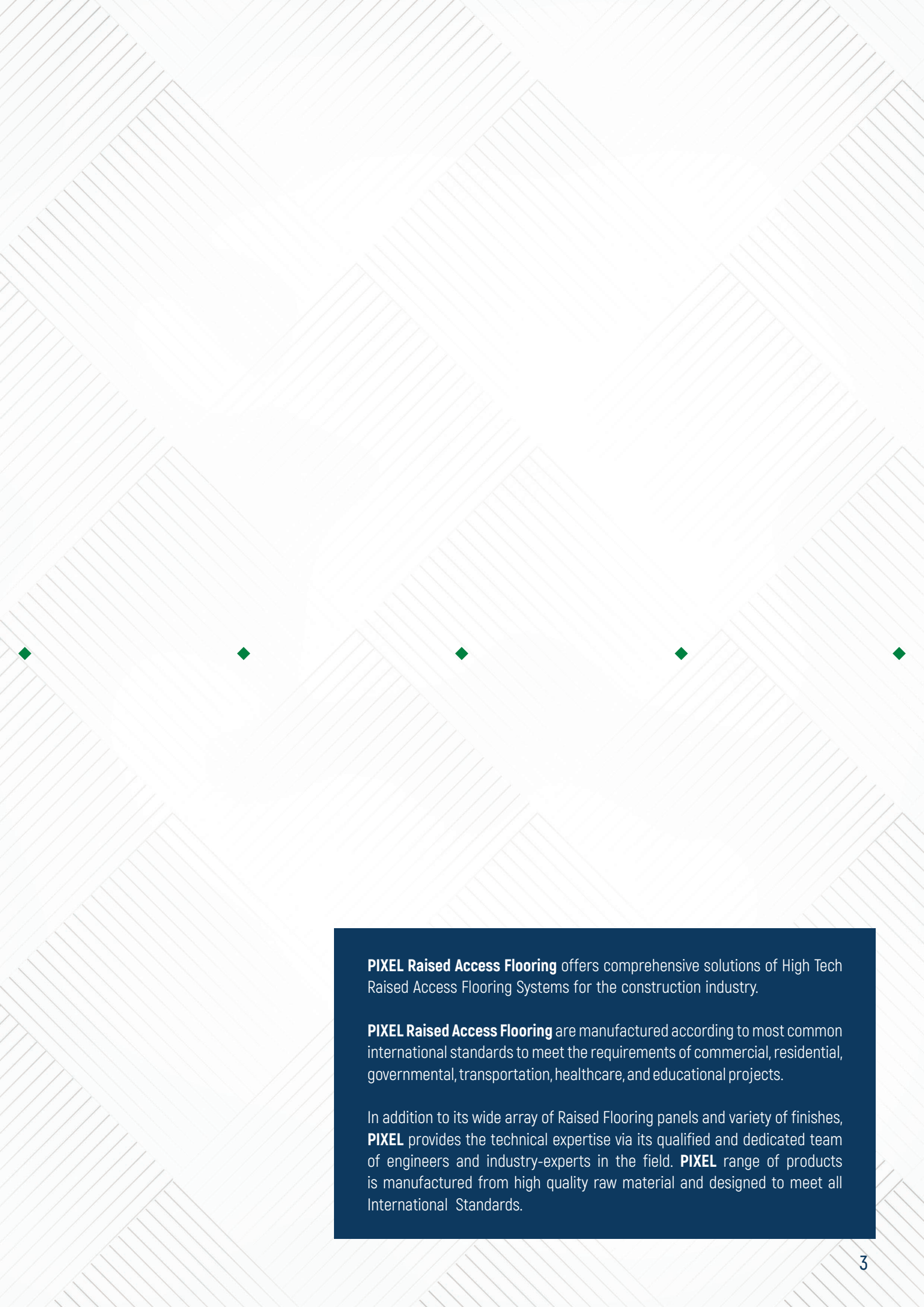

**PIXEL Raised Access Flooring** offers comprehensive solutions of High Tech Raised Access Flooring Systems for the construction industry.

**PIXEL Raised Access Flooring** are manufactured according to most common international standards to meet the requirements of commercial, residential, governmental, transportation, healthcare, and educational projects.

In addition to its wide array of Raised Flooring panels and variety of finishes, **PIXEL** provides the technical expertise via its qualified and dedicated team of engineers and industry-experts in the field. **PIXEL** range of products is manufactured from high quality raw material and designed to meet all International Standards.

## Scope of Application

Raised access flooring system is an elevated floor that is laid above a sub-floor, in order to leave an open space or void.

Raised floor system was commonly used in data centers and computer rooms. Nowadays, and due to the increased application of advanced technology which requires proper cable management, Raised Flooring through their flexibility has become a key component in today's intelligent buildings and an effective solution in General Offices, Schools, Universities, Power Stations, Labs, and others.



## Benefits of Raised Flooring

The most common usage for access floors is to run cables, electrical wiring and HVAC ducts. Running cables and electrical wiring through the accessible space between the panels and the sub-floor allows easy access and flexibility; wiring can be rerouted, repaired and upgraded without construction and minimal interference to the business' everyday activity. When combined with modular electrical systems and modular walls, the entire building can be reconfigured in a fraction of the time it would traditionally take.

Heating and cooling a building with a raised flooring system is also more efficient. The empty space between the panels and the sub-floor acts as a plenum chamber to dispense conditioned air evenly throughout the building. Additionally, since warm air rises, heating the building from the access floor gap during the winter is more effective and efficient.

Raised floors are particularly useful for data centers and telecommunication facilities. Computer systems can rest on perforated tiles so that conditioned air is accessible for each unit. The equipment can then be designed to draw the cool air from below. With the increased efficiency and accessibility, access floors are an ideal alternative to suspended ceilings.

## Composition

Raised Access Flooring System is a combination of panel bearing laid down on stringers and pedestals.

### PANELS:

PIXEL Raised Flooring offers a variety of panels including calcium sulphate panels, cementitious steel composite Panels, and Chipboard panels as well.

Pixel panels are fabricated with bare finish, or covered with anti-static finishes such as high pressure laminate floor cover, vinyl floor covering, ceramic finish, and carpet, etc.

### PEDESTALS:

PIXEL Galvanized Steel Pedestals: A vertical, adjustable part that supports the floor panels, with heights ranging from 100mm up to 2000mm. (The height of the under structure system is dictated by the volume of cables and other services to be stored beneath the raised floor). The panel is attached to the pedestal head at each corner. These pedestals are usually bonded to the sub-floor with mechanical fixings.

### STRINGERS:

Stringers are horizontal pieces that connects to the pedestal heads, adding additional lateral floor support, while needed.



## Standards

**PIXEL Raised Access Flooring Systems** are designed to meet the requirements of International Standards to achieve the highest quality, ASTM-CISCA American standards and UNE EN 12825 European Standards.

**PIXEL Raised Access Flooring Systems** are manufactured according to market requirements and is dependent on the type of traffic and static or dynamic load it will bear.

## Production - Inspection Standards

Every component of PIXEL Raised Access Flooring is regularly checked during production process with our own measurement equipment laboratory following a rigorous control method to the highest standards.



### Dimensional Tolerance

Panel Side Length Tolerance:	±0.2 mm
Panel Squareness:	±0.3 mm
Straightness of Sides:	±0.3 mm
Panel Thickness Tolerance:	±0.3 mm
Panel Twist:	0.5 mm
Panels Vertical Wrapping:	0.3 mm
Difference in Height Between Perimeter Trims and Panel Surface:	±0.3 mm

**Note:** Limit panel thickness tolerance of the same batch floor is 0.3 mm.

## Mechanical properties

### • Load Performance of the Floor.

The load bearing capability of a raised access flooring system is determined by the type of access flooring panel specified.

PIXEL									
Type	Concentrated Load(deflection=2mm)		Deflection (mm)	Permanent Deformation (mm)	Impact	Ultimate	Uniform	Rolling Load	
	N	Kg			Load (N)	Load (N)	Load (N/m)	10 Passes (N)	10000 Passes (N)

### • Impact Resistance

After the floor impact performance test, the permanent deformation of the floor surface should be  $\leq 1.5$  mm, and there should be no damage.

## Anti-static panel covering wear resistance

Material	Abrasion Resistance	Wear Resistance
HPL		
Vinyl		

## Pedestal Axial Load:

Axial load of adjustable pedestals should be  $> 20$  kN.

## Fireproof Performance

The fireproof performance of PIXEL Raised Access flooring reaches B1 and A levels.

## Floor Appearance

Raised access flooring should be assembled finely, keeping the seams neat and tidy, firmly bonded, with no opened glue. Surface covering and finishes should be stain-resistant, non-slippery slip, with no visible chromatic aberration, blistering and defect, and without glaring, .

The metal surface features a strong anti-rust layer.

The floor with galvanizing should have a metallic luster and no defects. The floor treated with spraying should be soft light, without obvious color difference, foaming and defects.





# PIXEL Chipboard Panel PIX-WOOD

PIX-CAL raised access flooring is made of high density chipboard core material. The top surface can be covered with multiple floor covering such as HPL, Vinyl, Carpet, Ceramic, etc. The bottom surface of the panel is covered with aluminum foil and galvanized steel sheet.

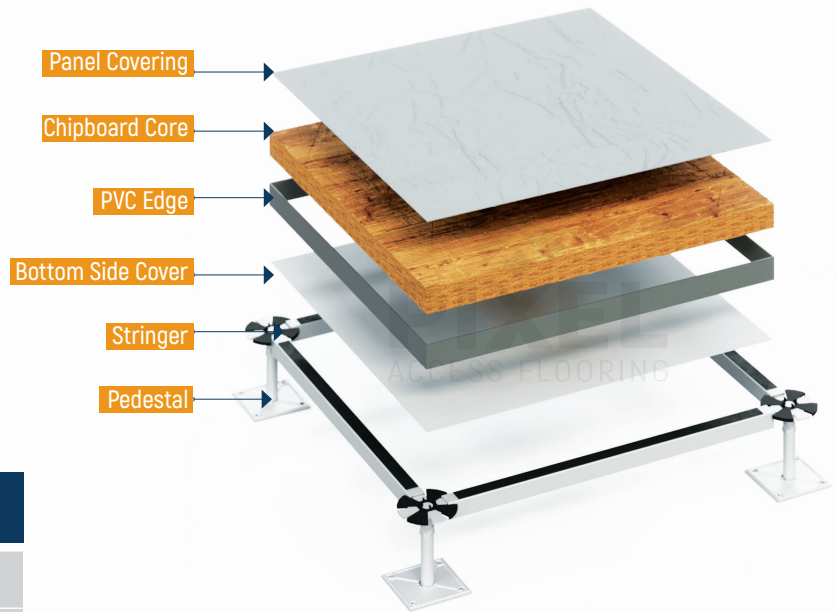

## Panel Dimensions/Weight

Size	Thickness	Weight
600x600 mm	35 and 38 mm	12-14 Kg.

### Electrical Resistance (EN 1081):

$> 1 \times 10^9 \Omega$

### Fire Performance:

Class B1

### Fire Classification:

Bfl - S1

## PIXEL Chipboard Panels

Type	Concentrated Load(deflection=2mm)		Deflection (mm)	Permanent Deformation (mm)	Impact Load (N)	Ultimate Load (N)	Uniform Load (N/m <sup>2</sup> )	Rolling Load	
	N	kg						10 Passes (N)	10000 Passes (N)
PIW 4.0	≥3972	≥400	≤ 2	≤ 0.25	670	11916	20500	3520	2500
PIW 4.5	≥4450	≥450			670	13350	23000	3658	3169
PIW 5.0	≥4965	≥500			670	14895	25500	4065	3520
PIW 5.6	≥5560	≥560			670	16680	33000	4558	3658
PIW 6.5	≥6375	≥650			670	19125	39430	5430	4356

- Load Class according to EN 12825: Class 5-6
- Safety factor: 3 (Class B)

# PIXEL Steel - Cementitious Panel PIX-STEEL

PIX-STEEL raised access flooring consists of epoxy coated hard steel top plate formed through stamping and spot welding to deep stretched steel tray, filled with foaming cement in the middle.

The combination of steel and concrete provides economic series of product grades, capable of matching the most demanding requirements. Panels are made either with bare finish (Epoxy coated), or with anti-static finishes with high pressure laminate or with vinyl, ceramic finish, and carpet, etc.

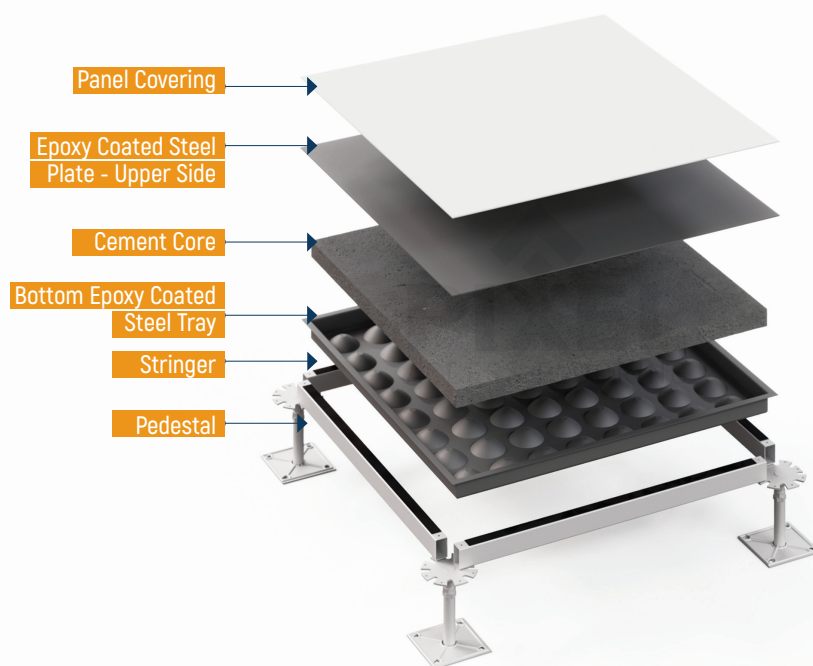

## Panel Dimensions/Weight

Size	Thickness	Weight
600x600 mm	35 mm	13-15 Kg.

### Electrical Resistance (EN 1081):

> 1 x 10<sup>9</sup>Ω

### Fire Performance:

Class A

### Fire Classification:

A2fl - S1

### PIXEL Cementitious Panels

Type	Concentrated Load(deflection=2mm)		Deflection (mm)	Permanent Deformation (mm)	Impact Load (N)	Ultimate Load (N)	Uniform Load (N/m <sup>2</sup> )	Rolling Load	
	N	kg						10 Passes (N)	10000 Passes (N)
PIS 3.0	≥2950	≥300	≤ 2	≤ 0.25	450	8850	12500	2250	1612
PIS 3.6	≥3550	≥360			670	10700	17000	3169	2250
PIS 4.5	≥4450	≥450			670	13350	23000	3658	3169
PIS 5.6	≥5560	≥560			670	16680	33000	4558	3658
PIS 6.8	≥6670	≥680			670	20000	41250	5690	4558
PIS 9.0	≥8900	≥908			670	26700	49584	6800	5690

- Load Class according to EN 12825: Class 3-6
- Safety factor: 3 (Class B)

# PIXEL Calcium Sulphate Panel PIX-CAL

PIX-CAL raised access flooring panels are manufactured from high strength non-combustible Calcium Sulphate using environmental friendly materials: ~ 90% gypsum (calcium sulphate semi-hydrate), ~ 9% cellulose fibers.

Calcium Sulphate panels can be covered with a variety of finishes including HPL, Vinyl, Carpet, Ceramic, and others.

The Bottom surface is covered with Aluminum foil and galvanized steel sheet.

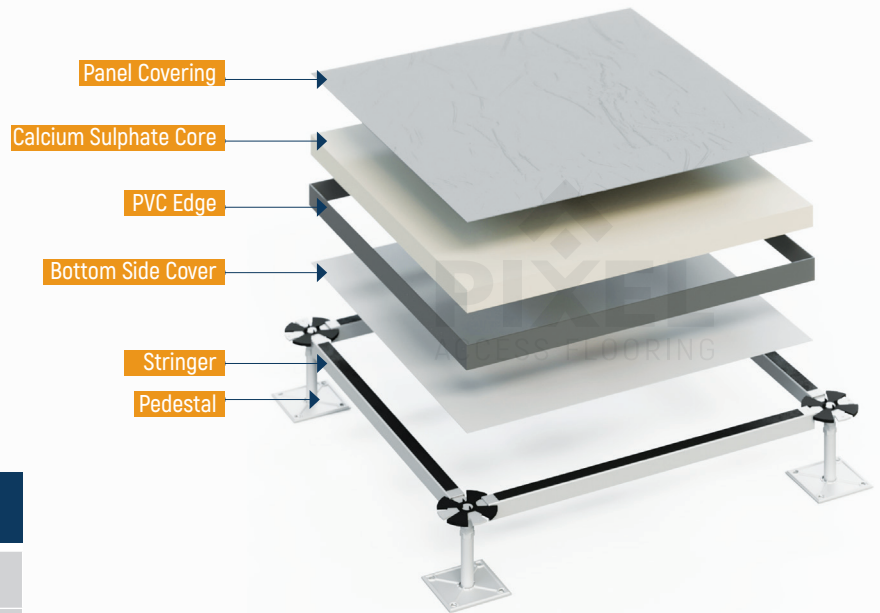

## Panel Dimensions/Weight

Size	Thickness	Weight
600x600 mm	30, 32, 38 mm	20-26 Kg.

### Electrical Resistance (EN 1081):

$> 1 \times 10^9 \Omega$

### Fire Performance:

Class A

### Fire Classification:

A2fl - S1

## PIXEL Calcium Sulphate

Type	Concentrated Load(deflection=2mm)		Deflection (mm)	Permanent Deformation (mm)	Impact Load (N)	Ultimate Load (N)	Uniform Load (N/m <sup>2</sup> )	Rolling Load	
	N	kg						10 Passes (N)	10000 Passes (N)
PICA 3.6	≥3550	≥360	≤ 2	≤ 0.25	670	10700	17000	3169	2250
PICA 4.5	≥4450	≥450			670	13350	23000	3658	3169
PICA 5.6	≥5560	≥560			670	16680	33000	4558	3658

- Load Class according to EN 12825: Class 5-6
- Safety factor: 3 (Class B)

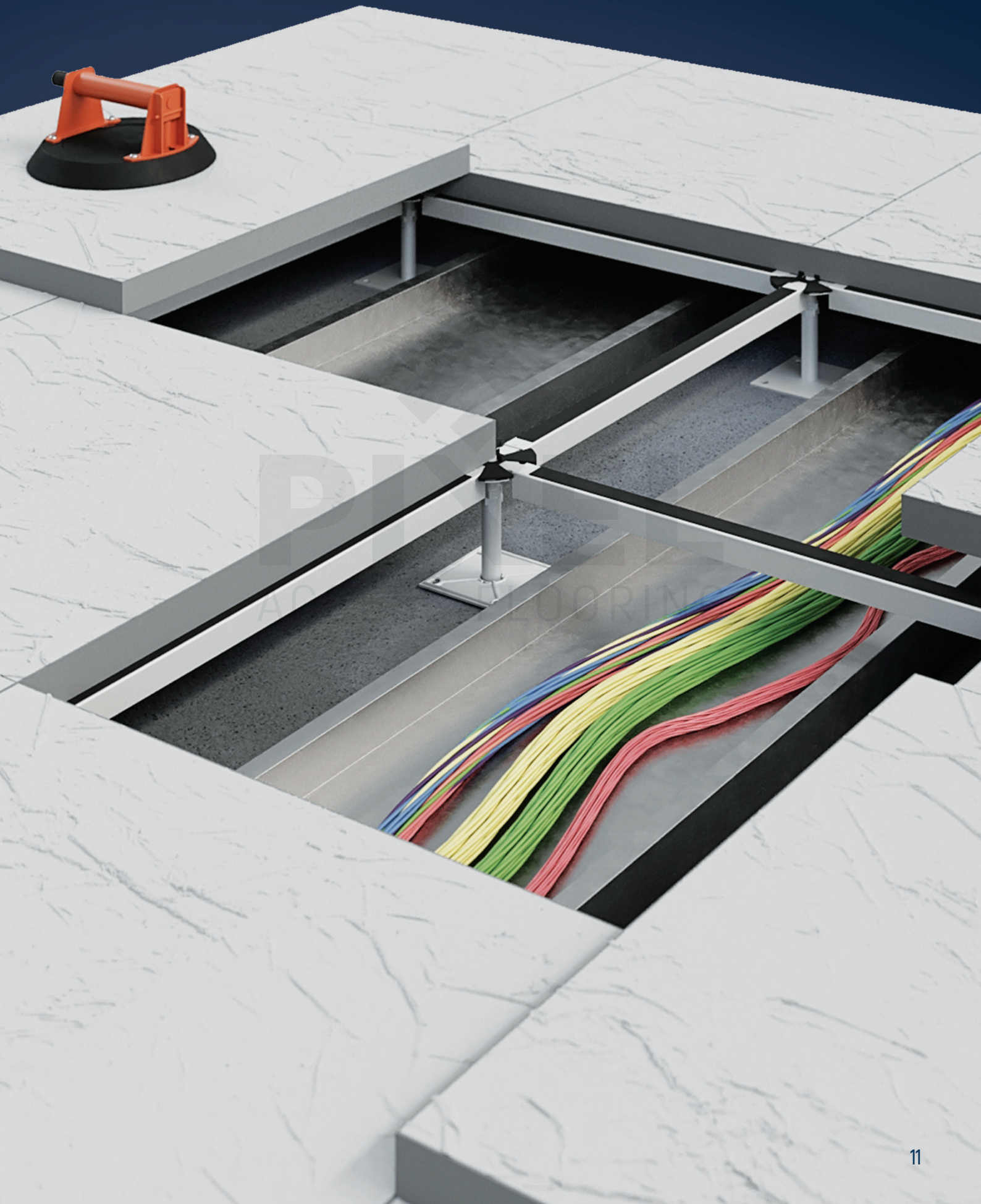

# PIXEL UNDER-STRUCTURE SYSTEM

## PEDESTALS

### Type 1: PIXPD-F

Height: 75-500 mm

#### Pedestal Head:

Electro galvanized circular steel of 98mm diameter x 2.3mm thickness welded at the center to M18 threaded steel with 2 leveling and locking nuts.

#### Pedestal Base:

Electro galvanized steel Plate.

Dimensions: 100x100mm with 2.3mm thickness, welded at the center to 21mm diameter tube. Thickness is 1.2mm.

Code	Pedestal Height (mm)	Adjustment Rang (mm)
PPF-1	75	75 - 100
PPF-2	100	100 - 125
PPF-3	150	125 - 175
PPF-4	200	175 - 225
PPF-5	250	225 - 275
PPF-6	300	275 - 325
PPF-7	350	325 - 375
PPF-8	400	375 - 425
PPF-9	450	425 - 475
PPF-10	500	475 - 525

### Type 2: PIXPD-S

Height: 510-1200 mm

#### Pedestal Head:

Electro galvanized circular steel

Dimensions: 98mm diameter x 2.3mm thickness welded at the center to M18 threaded steel with 2 leveling and locking nuts.

#### Pedestal Base:

Electro galvanized steel Plate,

Sizes: 100x100mm x 2.3mm thickness, welded at the center to 25mm diameter tube.

Thickness: 1.2mm.

Code	Pedestal Height (mm)	Adjustment Rang (mm)
PPS-1	550	525 - 575
PPS-2	600	575 - 625
PPS-3	650	625 - 675
PPS-4	700	675 - 725
PPS-5	750	725 - 775
PPS-6	800	775 - 825
PPS-7	850	825 - 875
PPS-8	900	875 - 925
PPS-9	950	925 - 975
PPS-10	1000	975 - 1025
PPS-11	1050	1025 - 1075
PPS-12	1100	1075 - 1125
PPS-13	1150	1125 - 1175
PPS-14	1200	1175 - 1225

# PIXEL UNDER-STRUCTURE SYSTEM

## PEDESTALS

### Type 3: PIXPD-T

Height: 1210-2000 mm

#### Pedestal Head:

Electro galvanized circular steel of 98mm diameter x 2.3mm thickness welded at the center to M18 threaded steel with 2 leveling and locking nuts.

#### Pedestal Base:

Electro galvanized steel Plate.

Sizes: 100x100mm x 2.3mm thickness, welded at the center to 32mm diameter tube,.

Thickness: 1.2mm.

Code	Pedestal Height (mm)	Adjustment Rang (mm)
PPT-1	1200	1175 - 1225
PPT-2	1250	1225 - 1275
PPT-3	1300	1275 - 1325
PPT-4	1350	1325 - 1375
PPT-5	1400	1375 - 1425
PPT-6	1450	1425 - 1475
PPT-7	1500	1475 - 1525
PPT-8	1550	1525 - 1575
PPT-9	1600	1575 - 1625
PPT-10	1650	1625 - 1675
PPT-11	1700	1675 - 1725
PPT-12	1750	1725 - 1775
PPT-13	1800	1775 - 1825
PPT-14	1850	1825 - 1875
PPT-15	1900	1875 - 1925
PPT-16	1950	1925 - 1975
PPT-17	2000	1975 - 2025

Axial Load: > 20 Kn.

Fire Performance: Class A.



# PIXEL UNDER-STRUCTURE SYSTEM

## STRINGERS

### S-shape

Electro galvanized steel square shape.  
Size: 25x25x0.9mm with polyethylene acoustic insulation.

This profile is suitable for calcium sulphate and chipboard panels.

### R-shape

Electro galvanized steel rectangular shape.  
Size: 32x21x0.9mm with polyethylene acoustic insulation.

This profile is suitable for cementitious panels only.

### Benefits:

- Enhance the load bearing capacity.
- Horizontal stiffening of the whole system.



# PIXEL UNDER-STRUCTURE SYSTEM

## BRACING

In order to enhance the stability and safety of raised flooring system with extremely high support heights, it is necessary to install additional bracing system on the original supporting structure to form a Seismic force-resistant structure.

Pixel bracing consists of a perforated galvanized steel strip of 20mm width and 1mm thickness, bolted to a substructure from one side and connected to a turnbuckle stretching screw.

A washer inserted to the pedestal is used as a connection.

Bracing Support

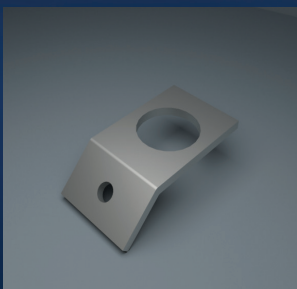

Galvanized Steel Washer



Turnbuckle



Perforated Steel Strip



Through Bolt



# VINYL COVERING

**Thickness** : 2mm  
**Weight** : 3980 g/m<sup>2</sup>

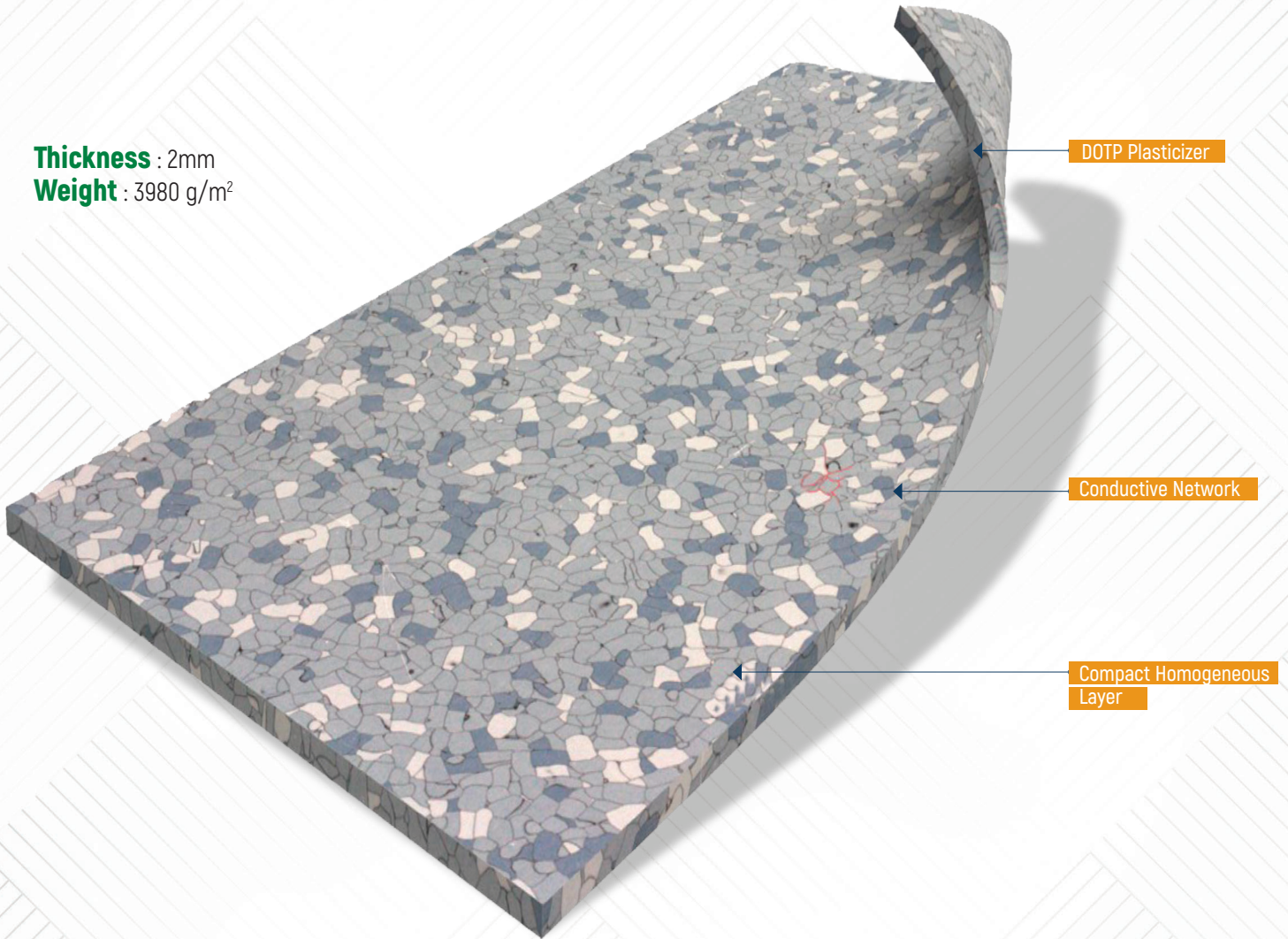

## ESD Tiles Main Ingredients

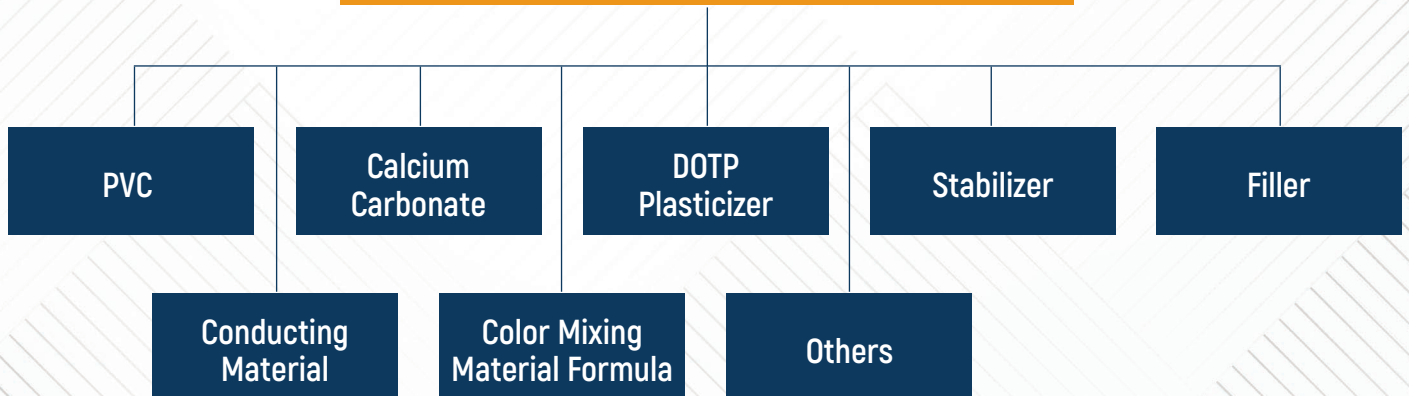

## Colors

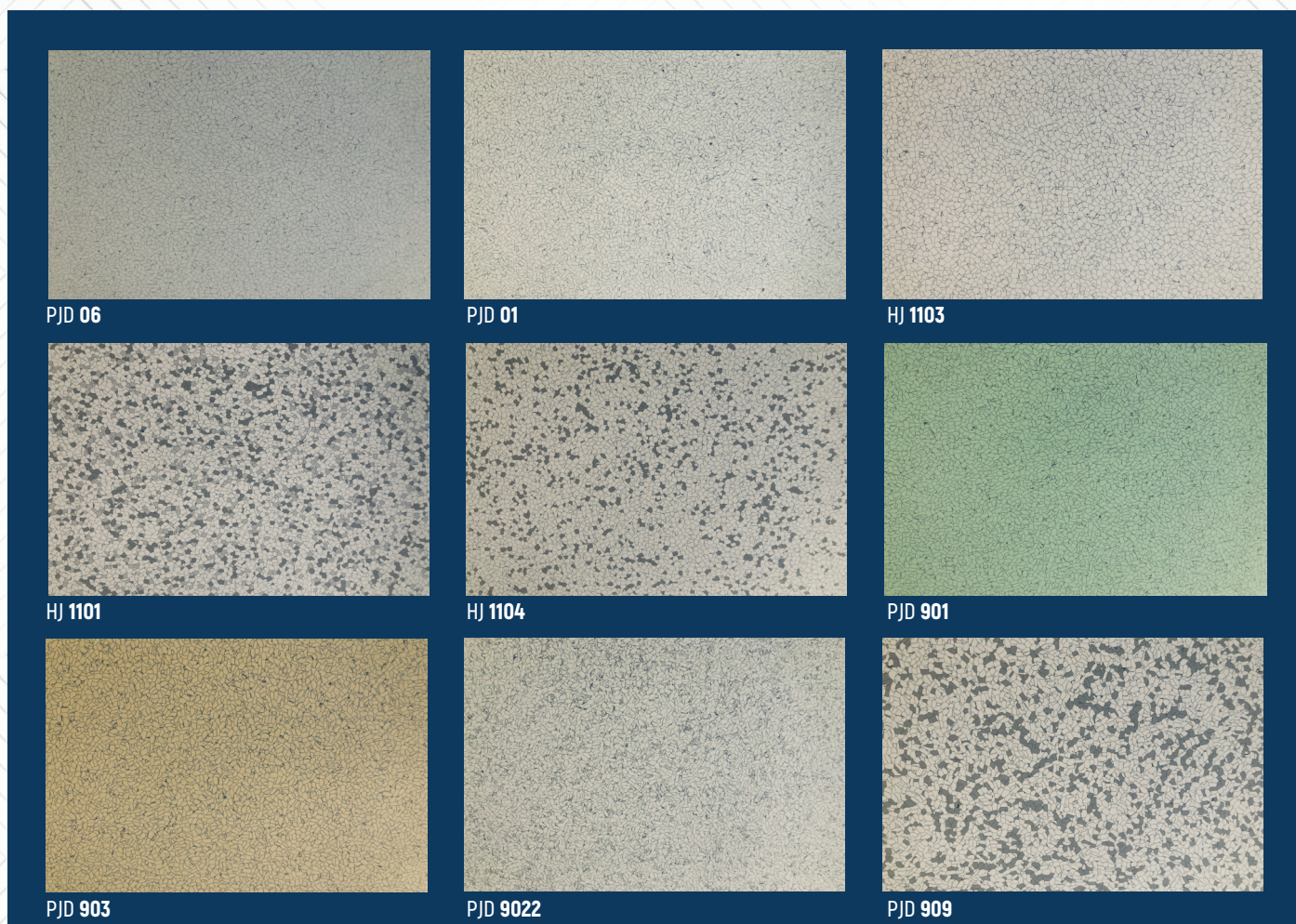

## Technical Data

Item	Standard	Technical Data	
Electrical Resistance( $\Omega$ )	SJ/T11236-2001	Conductive EC	Dissipative SD
		$2.5 \times 10^4 - 1.0 \times 10^6$	$1.0 \times 10^6 - 10^9$
Dimensional (%)	ISO 23999:2018	0.05	
Static Voltage	SJ/T11236-2001	50V	100V
Static Decay (s)	GJB2605-1996	$\leq 2$	
Wear Resistance	EN 660-2:1999	Class P	
Fire Resistance	EN13501-1:2007	Bfl-s1	
Radiant Flux ( $W/cm^2$ )	ASTM E648-2017	$\geq 1.1$	
Slip Resistance Wet	EN13893	$\geq 0.3$	
Residual Indentation (mm)	ISO 24343-1:2002	0.01	
Color Fastness	ISO 105B 02	$\geq 6$	
Chemical Products Resistance	EN ISO 26987:2012	OK	
Migration of Certain Elements	EN 71-3:2013	OK	
RoHS Directive (%)	EN 62321	0.003	
TVOC After 28 Days( $\mu g/m^3$ )	ISO 16000-3	<10	

# ANTI-STATIC HPL

High pressure laminate according to EN 438.

## Performance:

- High resistance to wear and tear
- High resistance to scratching
- High resistance to impact
- Resistance to high temperatures
- Special anti-static properties
- Easy cleaning and maintenance.



## Technical Data

Property	Test Method (EN 438:2005)	Unit	Values
Thickness	EN438-2.5	mm	0.9; 1.2; 2
Density	ISO 1183	gr/cm <sup>3</sup>	> 1,35
Impact Resistance	EN 438-2.20	N	> 20
Stain Resistance	EN 438-2.26	Rating	> 4
Resistance to wet heat	EN 12721	Rating	> 4
Resistance to abrasion	EN 13329 - Annex E	Revs	AC 2 IP > 1500
Electrical Resistance	DIN 51953 / EN 1081	Ω	Anti-static 1.0x10 <sup>6</sup> ~ 1.0x10 <sup>9</sup>



# PIXEL Perforated Panels

Perforated panels specially constructed to allow air flow distribution from under the raised access floor,,PIXEL Raised Access Flooring offers a wide range of steel perforated panels with or without damper for regulating air flow.

- Panel size: 600x600mm.
- Load ratings are equal to non perforated panels.
- Perforation rate: From 10% up to 48%.
- Panel finishing: Epoxy coated.

## 1) PIXEL - Perforated Type (PU)

This panel is applicable for all PIXEL Raised Access Flooring Panels.  
Thickness: 30 up to 45mm.

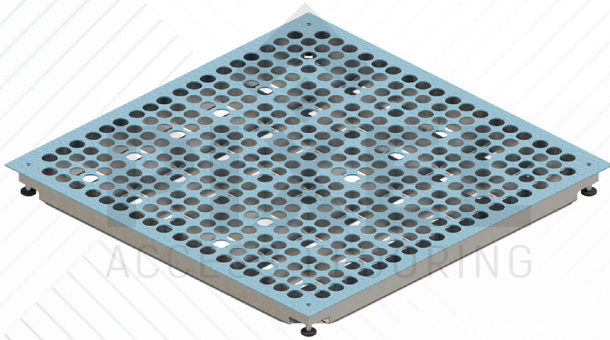

Ventilation Rate without Regulator	Hole Size Ø
12 %	11.75
18 %	14.40
24 %	16.60
26 %	17.30
30 %	18.50
36 %	20.30
42 %	22.00
48 %	23.50

## PU Panel Regulator

Maximum Ventilation Rate at 27%.

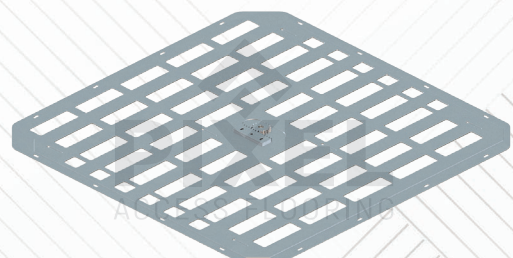
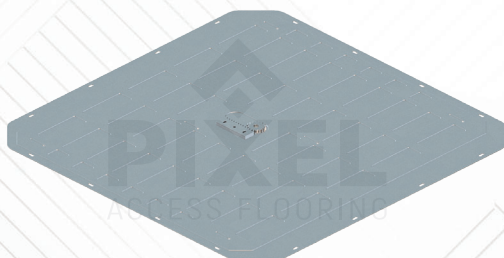

# PIXEL Perforated Panels

## 2) PIXEL - Perforated Type (CC)

These Panels are applicable for Chipboard and Calcium Sulphate panels.

### CC1

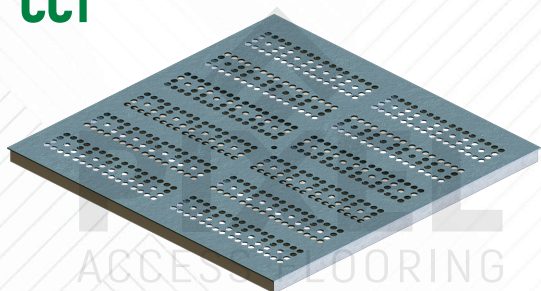

### CC2

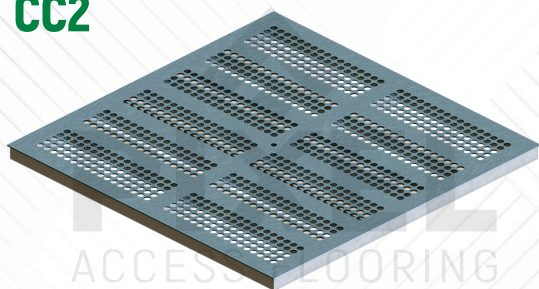

### CC3

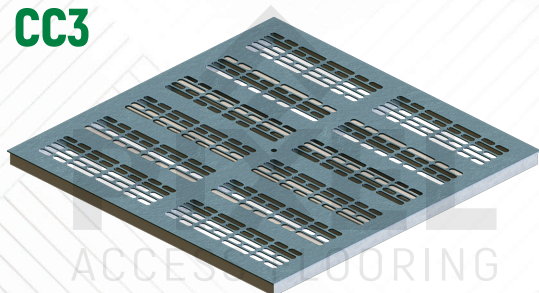

### CC4

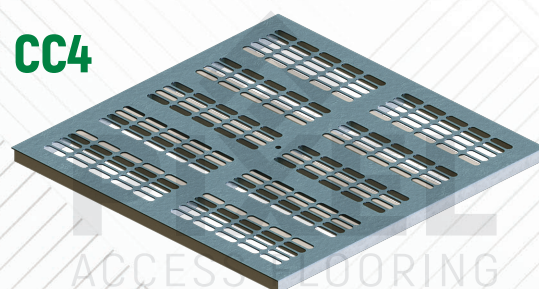

Ventilation Rate without Regulator	Hole Size $\varnothing$
10 %	8.5
12 %	9.5
14 %	10
16 %	11
18 %	11.5

Ventilation Rate without Regulator	Hole Size $\varnothing$
20 %	10.2
22 %	10.7
24 %	11.2
26 %	11.6
28 %	12.1

Ventilation Rate without Regulator	Slot 1 (mm)	Slot 2 (mm)
30 %	26.5 x 10	57 x 10
32 %	27 x 10.5	58 x 10.5
34 %	27.5 x 11	59 x 11

Ventilation Rate without Regulator	Slot (mm)
36 %	14 x 45
38 %	14.5 x 46

# PIXEL Perforated Panels

## 3) PIXEL - Perforated Type (CE)

These Panels are applicable for Cementitious panels only.

**CE1**

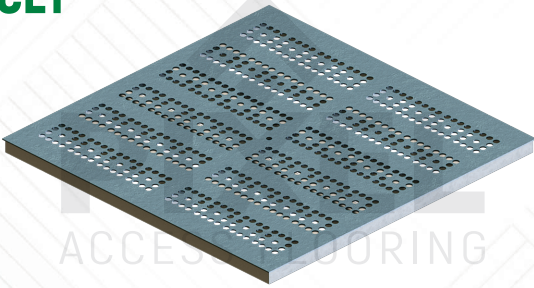

**CE2**

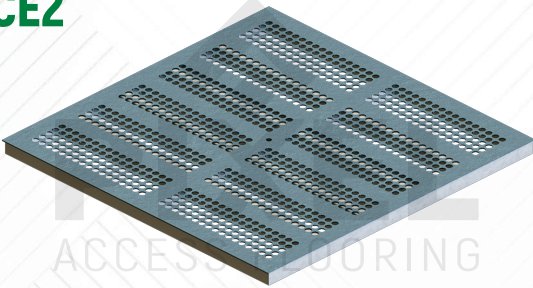

**CE3**

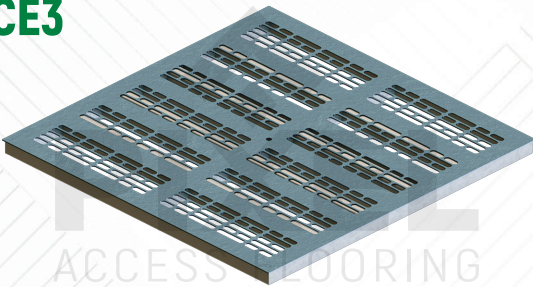

**CE4**

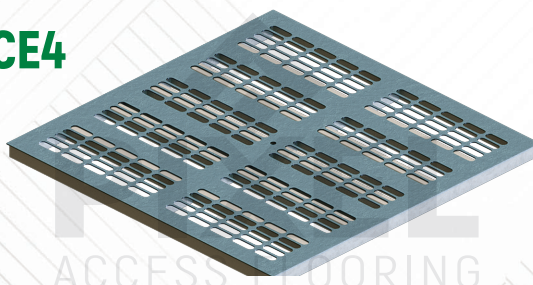

Ventilation Rate without Regulator	Hole Size Ø
10 %	8.5
12 %	9.5
14 %	10
16 %	11
18 %	11.5

Ventilation Rate without Regulator	Hole Size Ø
20 %	10.2
22 %	10.7
24 %	11.2
26 %	11.6
28 %	12.1

Ventilation Rate without Regulator	Slot 1 (mm)	Slot 2 (mm)
30 %	26.5 x 10	57 x 10
32 %	27 x 10.5	58 x 10.5
34 %	27.5 x 11	59 x 11

Ventilation Rate without Regulator	Slot (mm)
36 %	14 x 45
38 %	14.5 x 46

# PIXEL Perforated Panels

## PIXEL Regulator for CC and CE Panels

Maximum Ventilation Rate at 38%.

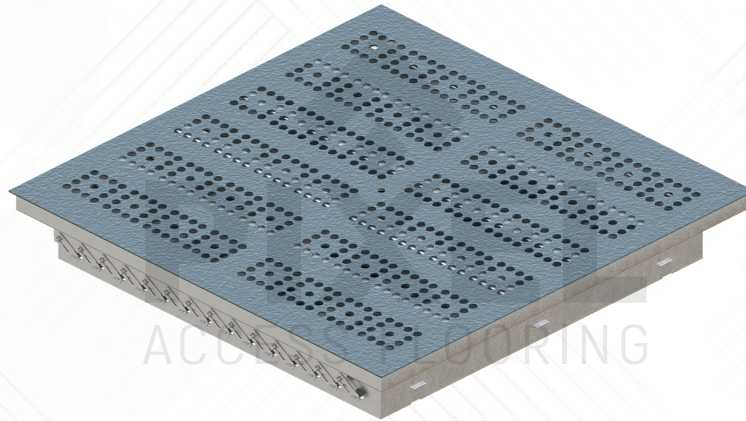

Directional Regulator

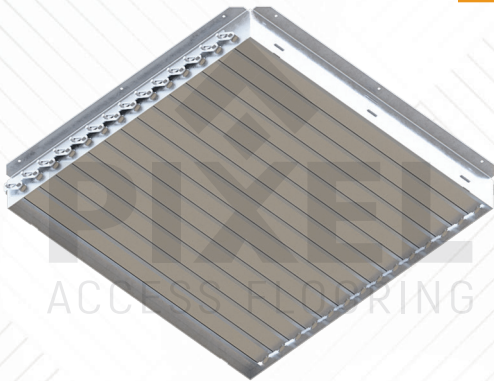

Closed Regulator



Open Regulator

## 4) PIXEL - Grills

### Type GR1:

Ventilation Rate: 88%  
This Panel is suitable for Calcium Sulphate and Chipboard Panels.  
Panel Size: 600 x 600mm

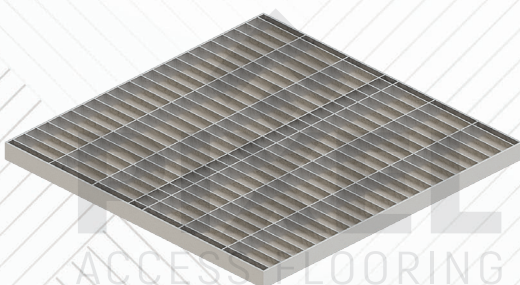

### Type GR2:

Ventilation Rate: 75%  
This Panel is suitable for Cementitious Panels.  
Panel Size: 600 x 600mm

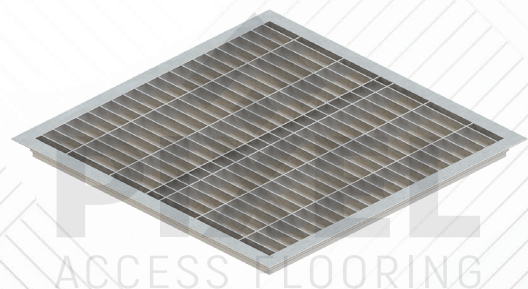



# PIXEL Raised Floor Service Power Boxes

PIXEL provides raised floor boxes for power outlets and data connections to desks and workstations within the modern office environment.

Designed and manufactured according to BS EN 60670-1:2005, BS EN 60670-23:2008.

- Available as standard type or heavy duty type.
- Boxes are supplied with dividers for quick and easy configuration as 3 or 4 compartment boxes that enables connection to a range of power, voice, and data socket plates.
- The standard support plate is 3mm thick and allows high traffic volume. In the case of very heavy traffic volume, a robust steel sub-frame can be used to support the lid.
- The sub-frame doesn't restrict space for wiring and accessories. It also allows fine adjustments to be made to accommodate uneven flooring.
- PIXEL floor boxes are made from galvanized steel and is available as stainless steel finish upon request.

## PIXEL - BOXES

### 1) PBOX 200218-2

2 compartments, 75 x 175mm  
Cutout size : 182 x 200mm

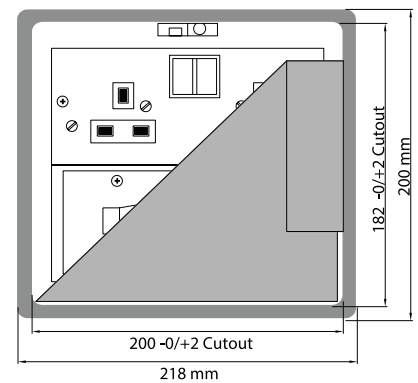
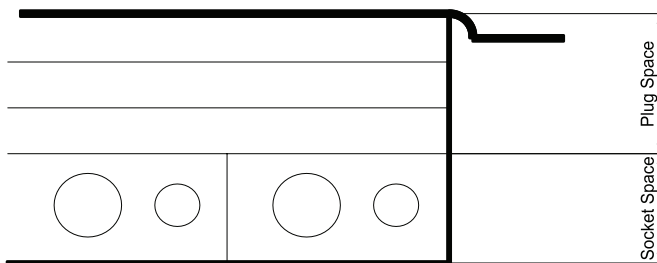

Size (mm)	No of Compartments	Plug Space (mm)	Socket Space (mm)
200 x 218	2	30-80	50

### 2) PBOX 250250-3

3 compartments  
75 x 205mm  
Cutout size : 232 x 232mm

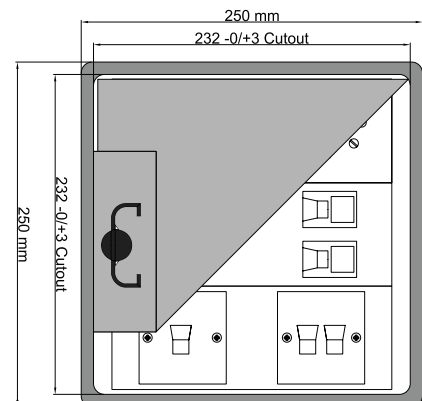

Size (mm)	No of Compartments	Plug Space (mm)	Socket Space (mm)
250 x 250	3	30-80	50

# PIXEL Raised Floor Service Power Boxes

## 3) PBOX 350223-3

3 compartments  
 100 x 180mm  
 Cutout size : 332 x 205mm

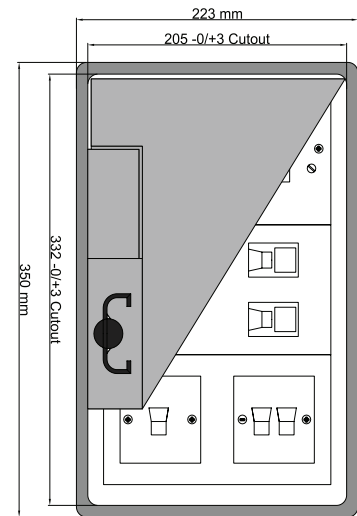
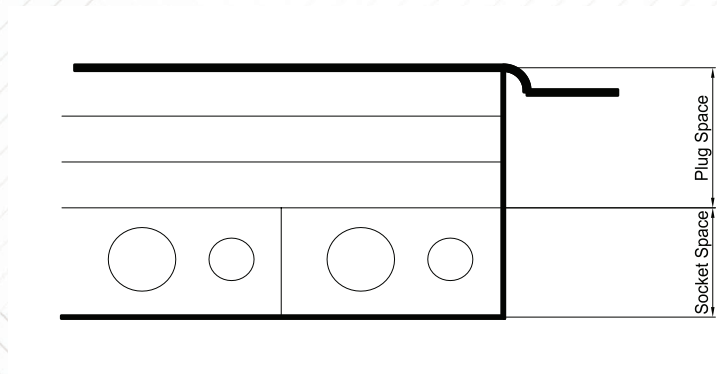

Size (mm)	No of Compartments	Plug Space (mm)	Socket Space (mm)
350 x 223	3	30-80	50

## 4) PBOX 350223-4

4 compartments  
 75 x 180mm  
 Cutout size : 332 x 205mm

Size (mm)	No of Compartments	Plug Space (mm)	Socket Space (mm)
350 x 223	4	30-80	50

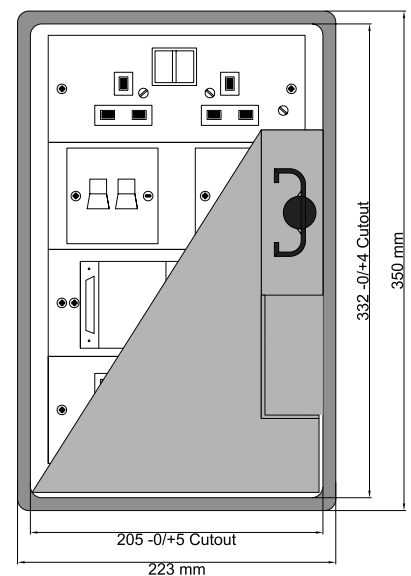

Other sizes are available upon request.

# Sales Offices

## **KINGDOM OF SAUDI ARABIA**

unitech.ksa@ikkgroup.com

### **Jeddah**

Tel : +966 12 627 8222

### **Mak kah/Taif**

Tel : +966 12 541 1206

### **Mad inah**

Tel : +966 14 842 1095

### **Yanbu**

Tel : +966 14 390 1499

### **Khamis Mushayt**

Tel : +966 17 237 5929

### **Gizan**

Tel : +966 17 321 6660

### **Riyadh**

Tel : +966 11 292 8200

### **Qassim / Buraidah**

Tel : +966 16 382 3946

### **Skakah / Qurayyat**

Tel : +966 14 626 3904

### **Tabuk**

Tel : +966 14 423 5203

### **Dammam**

Tel : +966 13 859 0097

### **Hofuf**

Tel : +966 13 530 1474

### **Jubail**

Tel : +966 13 361 4390

## **Bahrain**

unitech.bahrain@ikkgroup.com

### **Manama**

Tel : +973 17 874 897

## **Kuwait**

unitech.kuwait@ikkgroup.com

### **Kuwait City**

Tel : +965 2 4924 937

## **UNITED ARAB EMIRATES**

### **Dubai - Al Rashidiyah**

unitech.dubai@ikkgroup.com

Tel : +971 4 2591 773

### **Abu Dhabi - Musaffah**

unitech.auh@ikkgroup.com

Tel : +971 2 552 3393

## **LEBANON**

unitech.lebanon@ikkgroup.com

### **Beirut**

Tel : +961 1 858 277

## **OMAN**

unitech.oman@ikkgroup.com

### **Muscat**

Tel : +968 24 591 006

## **EGYPT**

unitech.egypt@ikkgroup.com

### **Cairo 6<sup>th</sup> of October City**

Tel : +20 2 3820 6477

## **PAKISTAN**

unitech.pakistan@ikkgroup.com

### **Lahore, Punjab**

Tel: +92 42 32301578

## **GERMANY**

unitech.germany@ikkgroup.com

### **Stuttgart**

Tel : +49 711 6868 7222

# Notes:



